

Highland Creek Fencing Design Guidelines

3.13.2 Fencing It is the intent of these guidelines to insure compatibility of fence design throughout the Highland Creek development by providing direction to homeowners for a harmonious use of fencing details and materials. There are three NCC approved fence designs included in this design manual, a wooden rail fence, a privacy fence and a privacy brick wall.

Optional Fence A - Brick Privacy Fence

Brick wall with cap and columns similar to wall constructed along Highland Creek Parkway. Appropriate for use in any village. See construction details on pages 3-37 and 3-38.

Optional Fence B - Wood Privacy Fence

"Shadow box" fencing made of 1"x6" pickets with "dog ear" tops, with identical appearance from both sides is the only wood privacy fence allowed. 4x4 posts shall extend above pickets and have a decorative beveled top with saw cut. Pickets are installed alternating on both sides of the rails so the appearance is the same from both sides of the fence. This Wood Privacy Fence is appropriate for any village. See details on page 3-39.

Optional Fence C - Wood Fence - All Villages Except Custom

3-rail, diamond-cut, split rail fence: 4"x4" rails and posts. 2"x2" galvanized, heavy gauge welded wire fabric screen may be secured to the inside of the rails to contain pets.

Optional Fence C - Wood Fence - Custom Villages

3-rail, diamond rail fence: 4"x4" rails and posts with bevel top posts with saw cut. See detail page 3-39. 2"x2" galvanized, heavy gauge welded wire fabric screen may be secured to the inside of the rails to contain pets. Please note: Split rail fences are not allowed.

All wood fences are to be left natural or given a semi-transparent stain in weathered wood colors. Solid body stains and painted fences are not allowed.

Highland Creek
Fencing Design Guidelines
(Supplemental)

3.13.2 Optional Fence D - Wood Picket Fence - All Villages

A 4' Virginia Gothic Picket Fence with matching Virginia Gothic-topped post (detail below). Pickets are 1"x4" and posts are 4"x4". There shall be two 2"x4" back runners with 2" spacing between the pickets. The picket side of the fence must face to the outside of the fenced property.

VIRGINIA GOTHIC PICKET

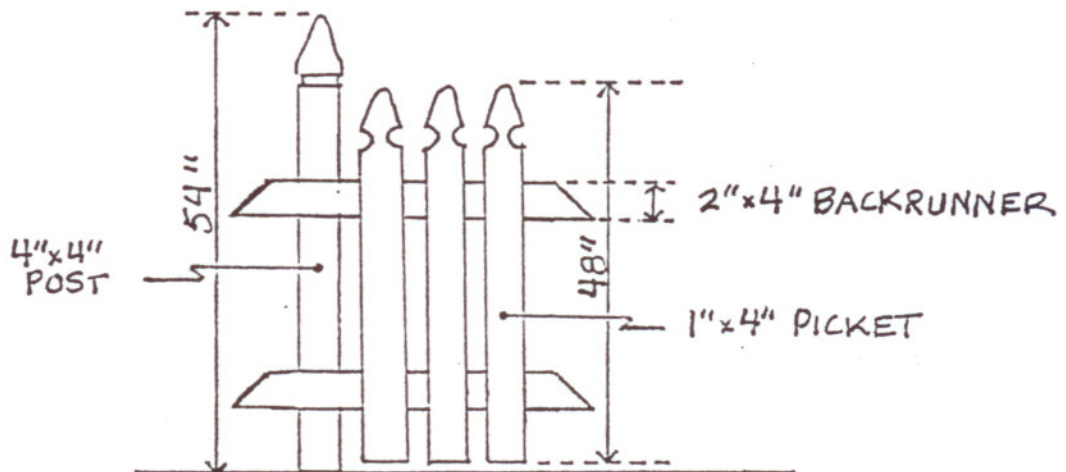

NOTE: All wood fences are to be left natural or given a semi-transparent stain in weathered wood colors. Solid body stains and painted fences are not allowed.

All fencing shall be erected at the option of the builder/owner. NCC approval of all fencing is required. A single fence shall be permitted between all contiguous lots sharing a common side or rear property line.

Except for walls by the Master Developer, fencing will not be allowed within front yards, and shall tie into the main structure at least thirty-six (36) inches back from the plane of the front facade.

No fencing shall be greater than six (6) feet in height and shall be less as specified under certain special conditions.

Gates may be installed and shall be designed to be compatible and complementary to the wall/fence design.

Should existing trees or other obstacles require adjustment to the fence location, the fence shall always be shifted in the direction of the private side.

Fences abutting the Highland Creek Parkway wall, Ridge Road wall, village entrance walls, or the transitional fence shall not exceed the height of the amenity wall/fence.

All privacy fences installed along a side property line abutting a local residential street shall have a minimum twelve (12) foot landscape buffer between the fence and the sidewalk.

Fencing along the golf course or common open space is permitted with the following stipulations. The fence is to be a wood rail fence four (4) feet in height installed at the rear property boundary. This fence must return down the side lot line thirty (30) feet. Privacy fencing on lots abutting the golf course or common open space must be set back thirty (30) feet from the property line adjacent to the golf course or common open space (typically the rear property line). Privacy fences running parallel with the golf course or common open space shall not exceed one-third (1/3) of the length of the property line.

The recommended method for installing a fence on a slope is to stair-step a fence evenly with the grade. Fences may also be allowed to run parallel to the grade.

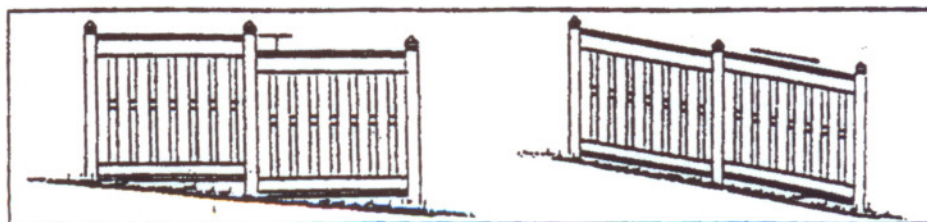

Step With Grade

Slope With Grade

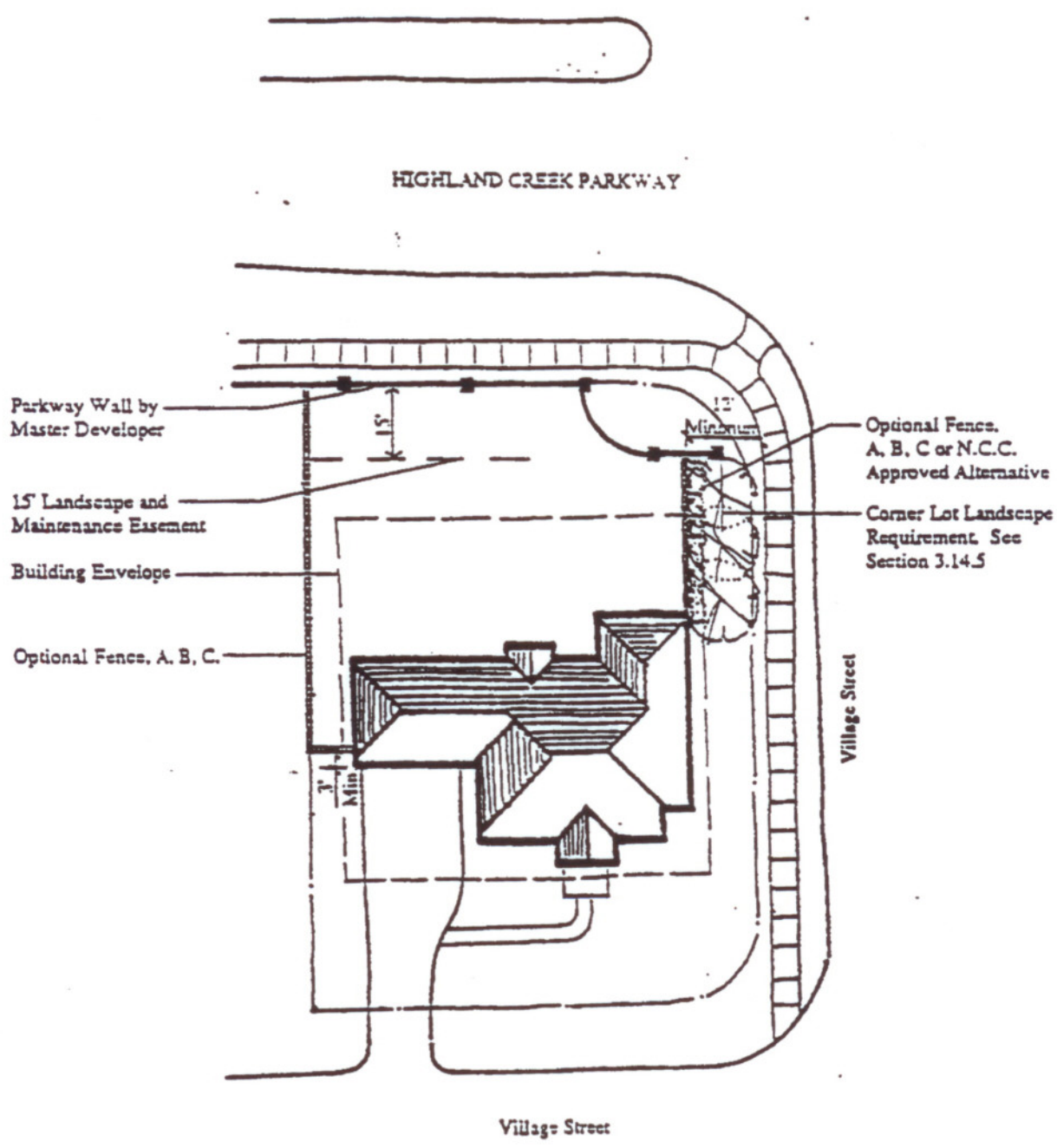

Fencing Options for
Through Lot at Village Entrance



HIGHLAND CREEK PARKWAY

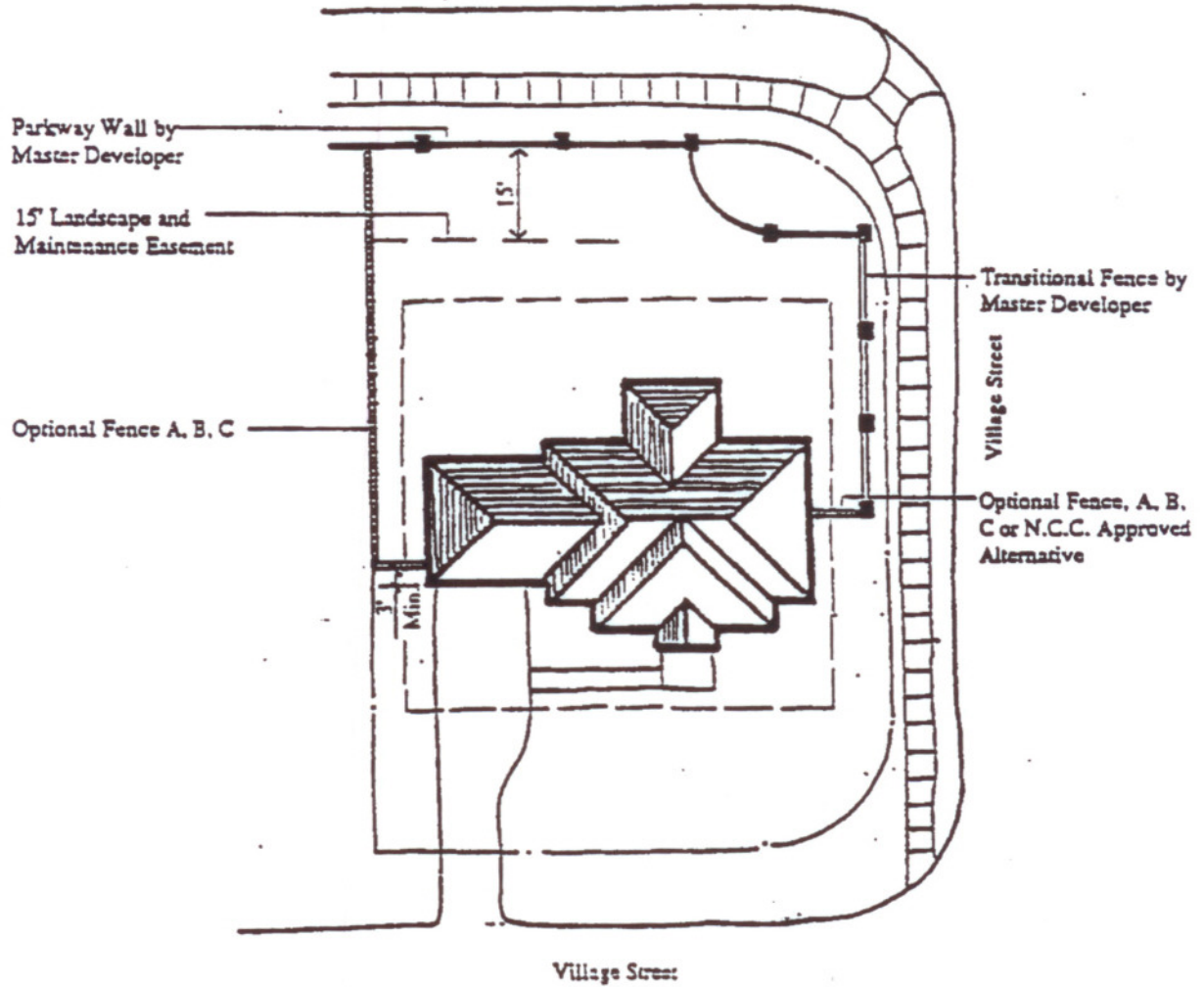

Fencing Option for
Through Lot at Village Entrance Transitional Fence Condition

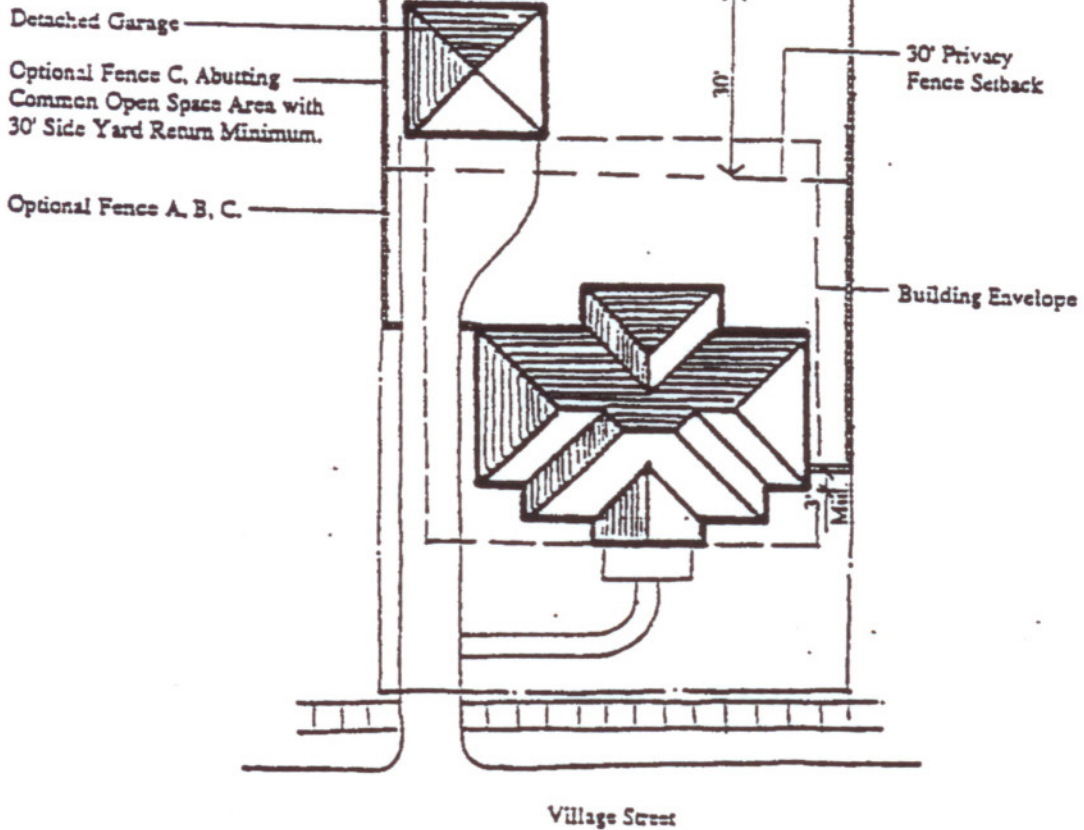
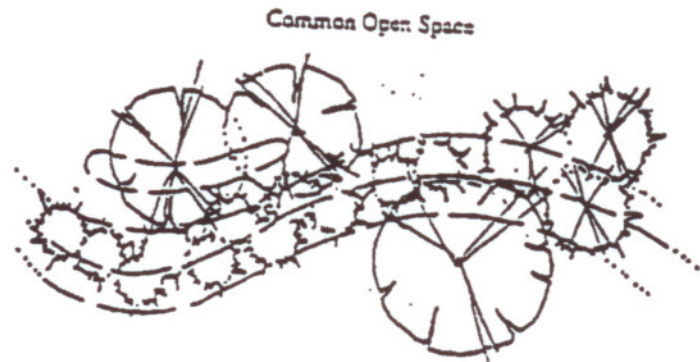

Fencing Option for Lot Abutting The Golf Course and Common Open Space Areas

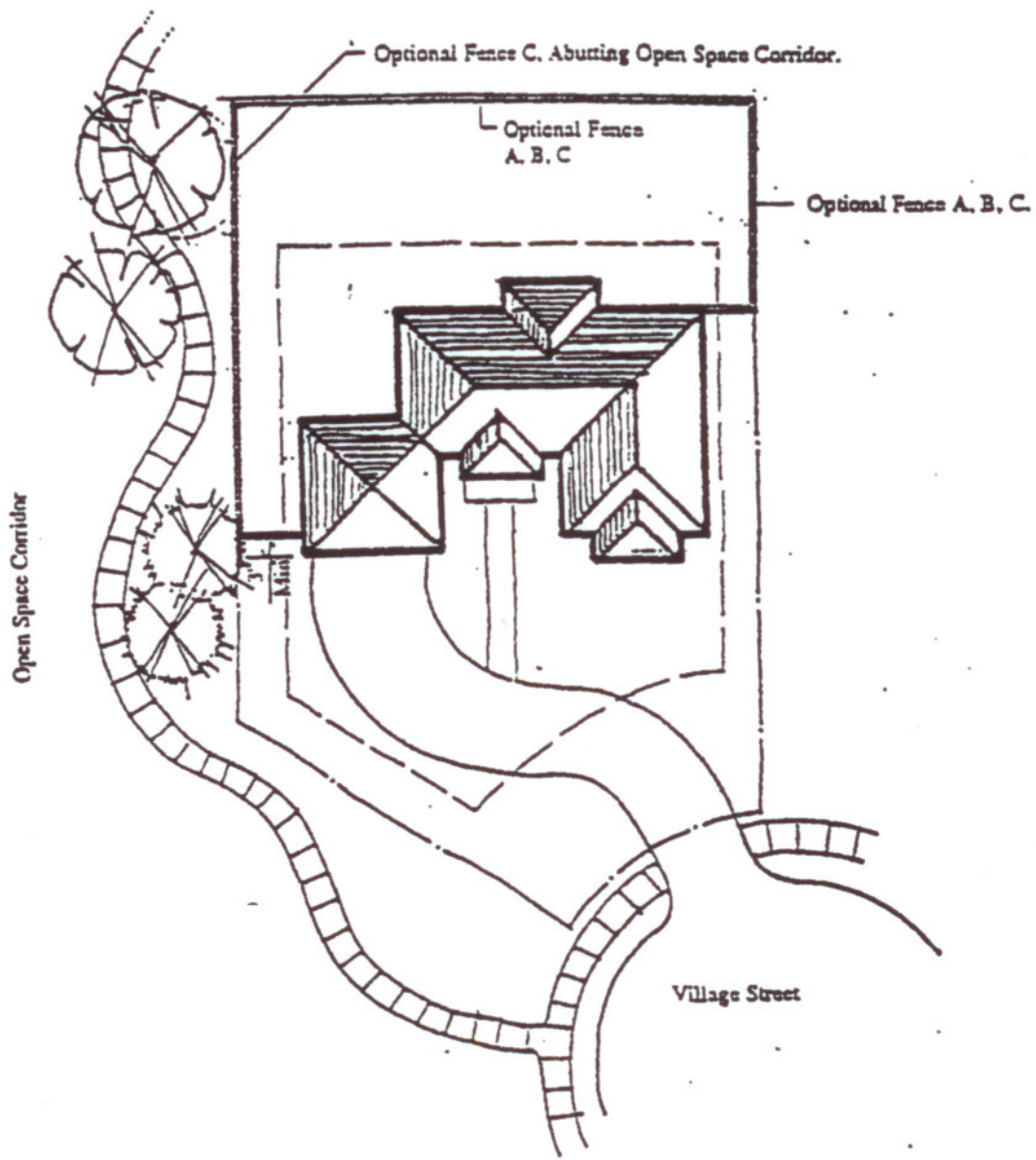

Fencing Options for
 Lot Abutting The Golf Course and Common Open Space Areas

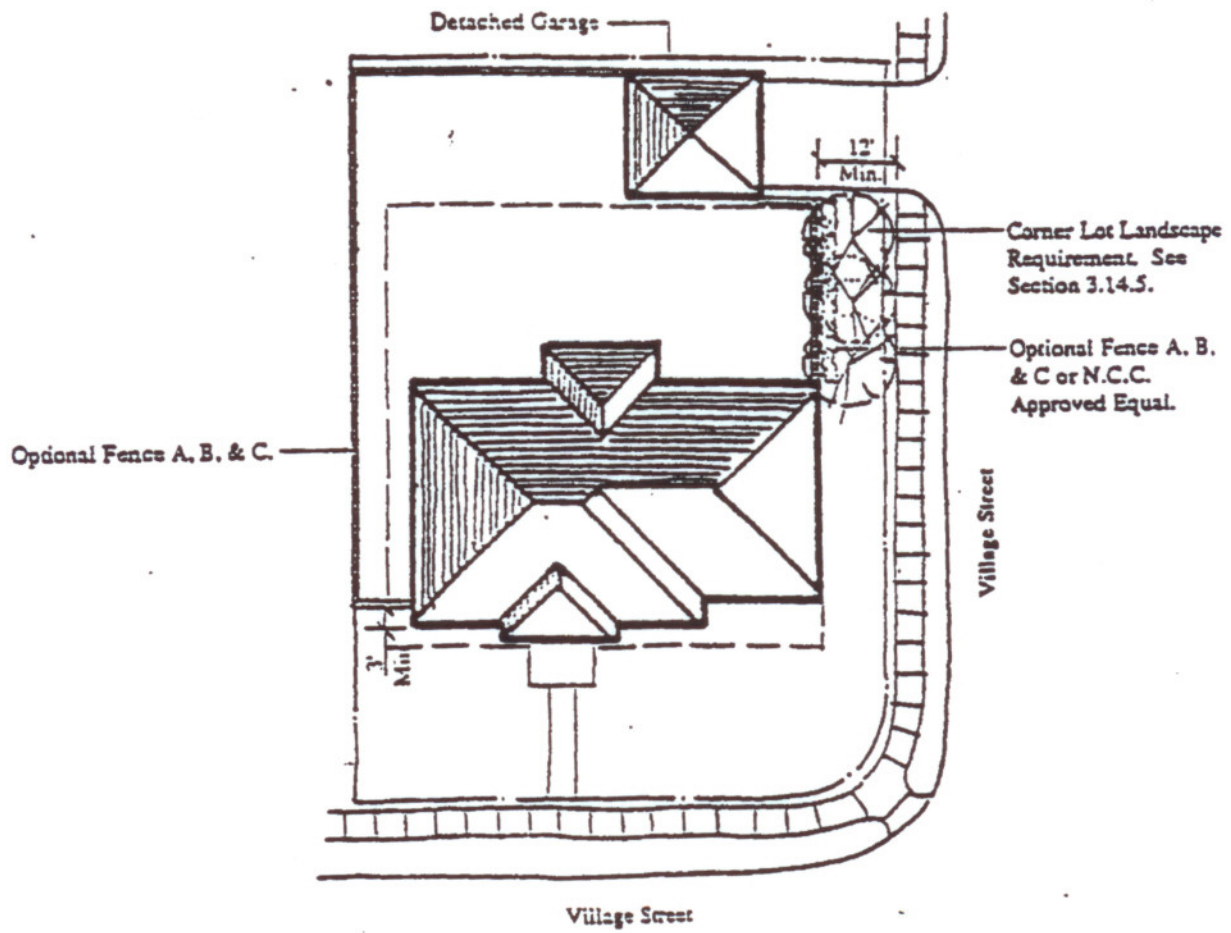

Fencing Option for
Corner Lot on Interior Street

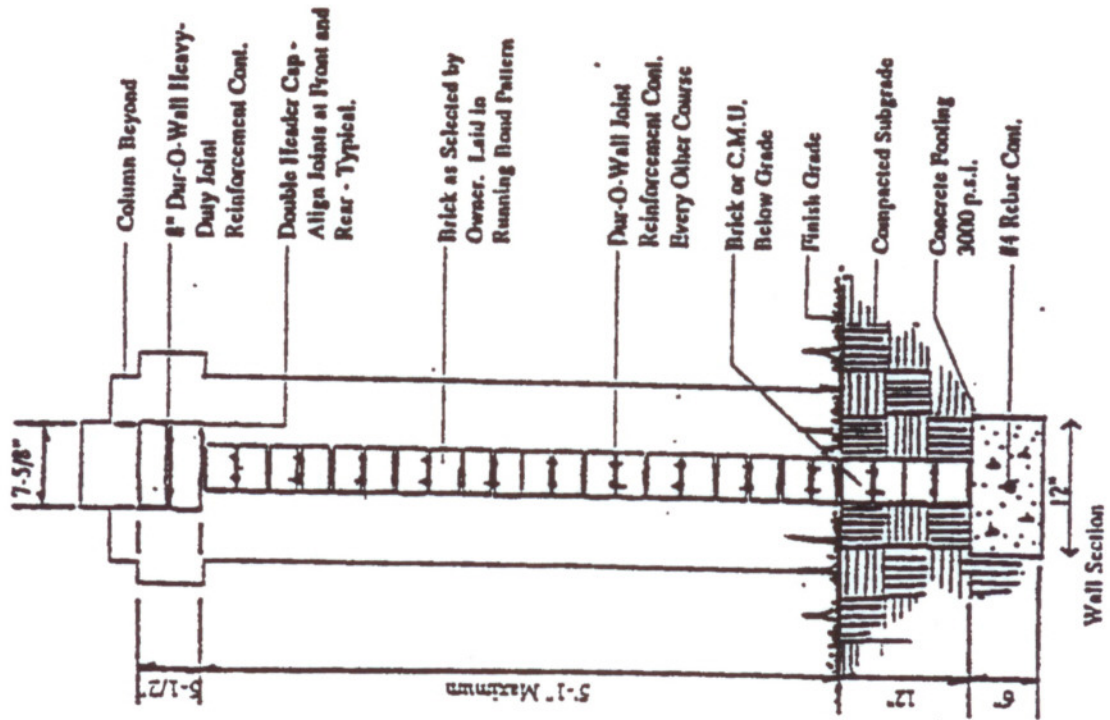
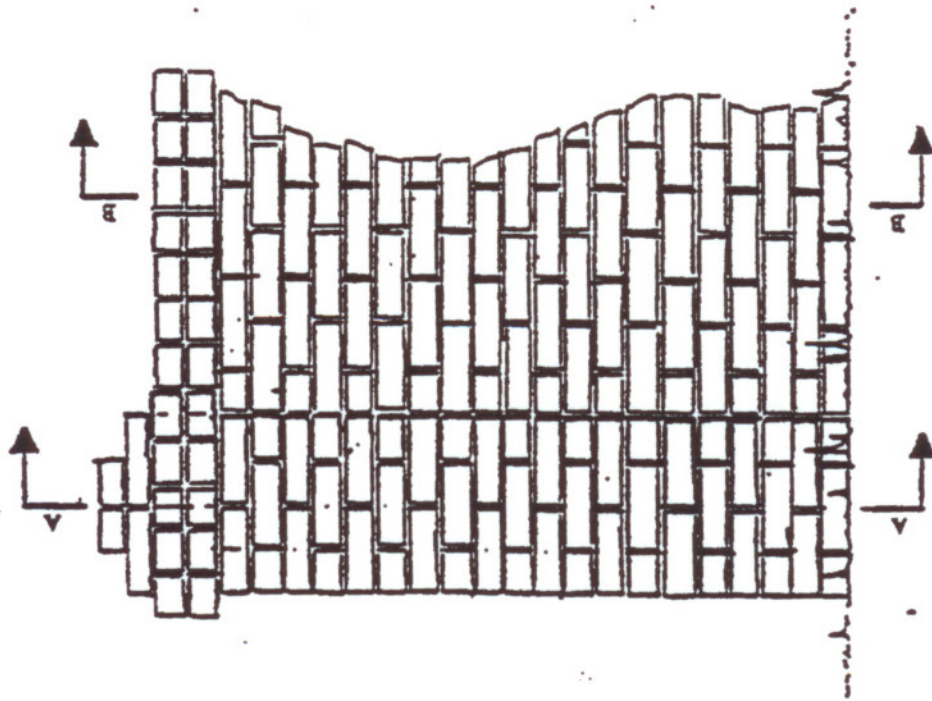

- Column Beyond
- 8" Dur-O-Wall Heavy-Duty Joint Reinforcement Cont.
- Double Header Cup - Align Joints at Front and Rear - Typical.
- Brick as Selected by Owner. Laid in Running Bond Pattern
- Dur-O-Wall Joint Reinforcement Cont. Every Other Course
- Brick or C.M.U. Below Grade
- Finish Grade
- Compacted Subgrade
- Concrete Footing 3000 p.s.i.
- #4 Rebar Cont.

7-5/8" 5'-1" Maximum 12" 6" 12"

A. Brick Wall

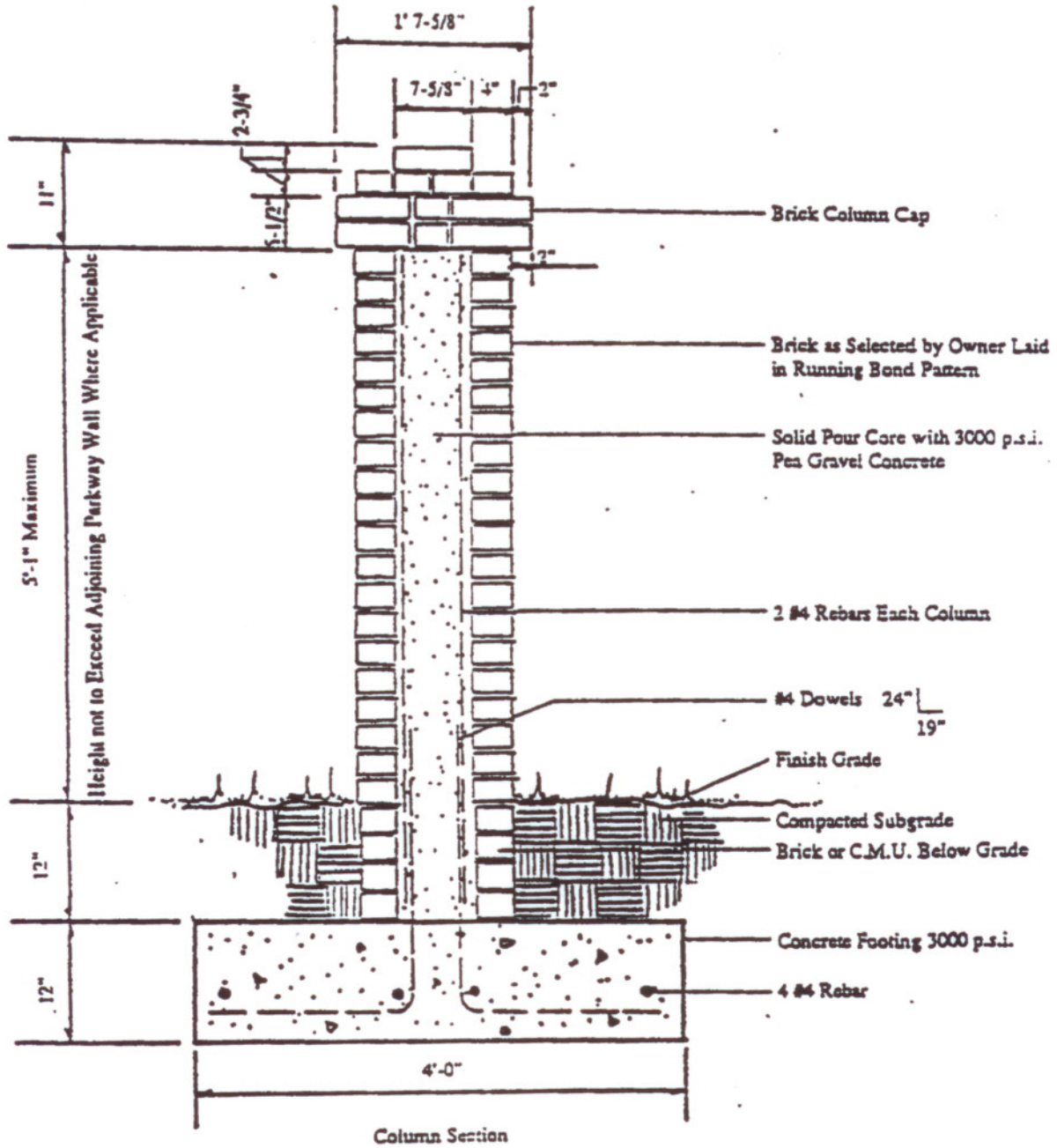

A. Brick Privacy Wall

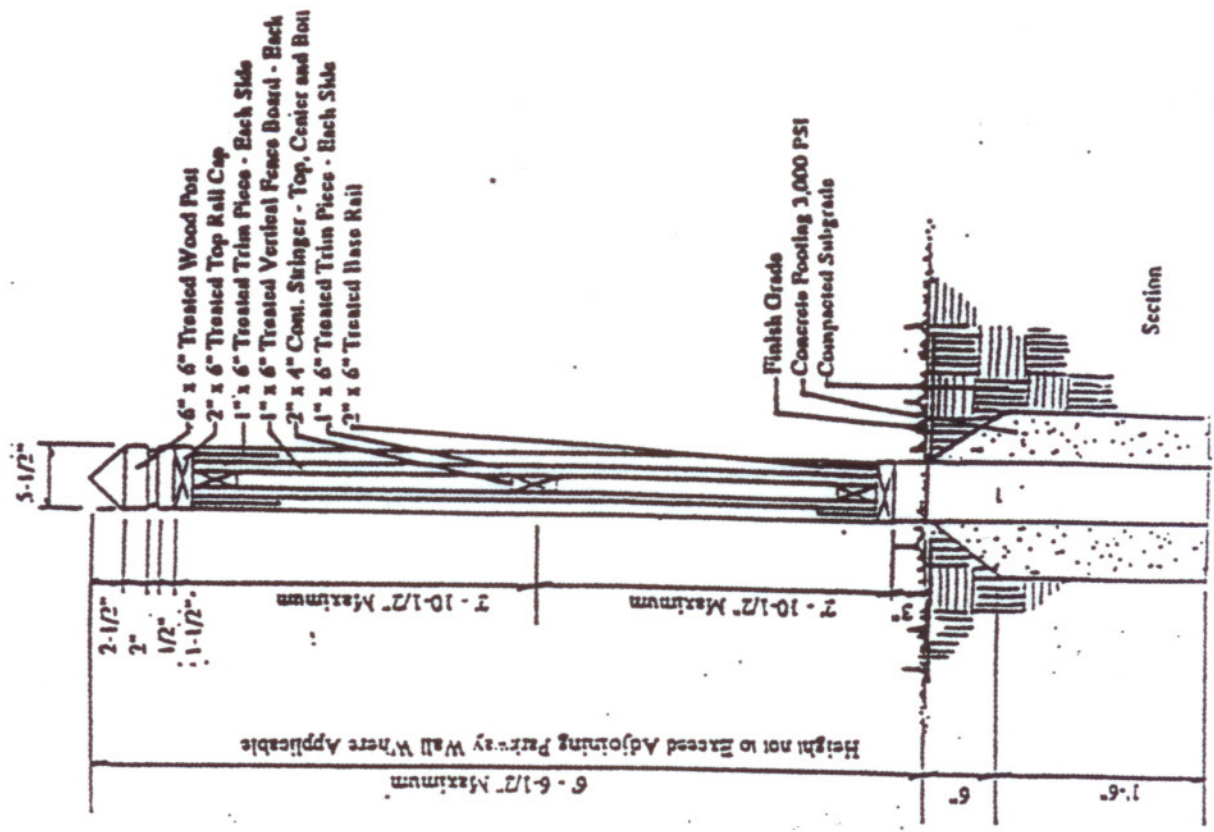
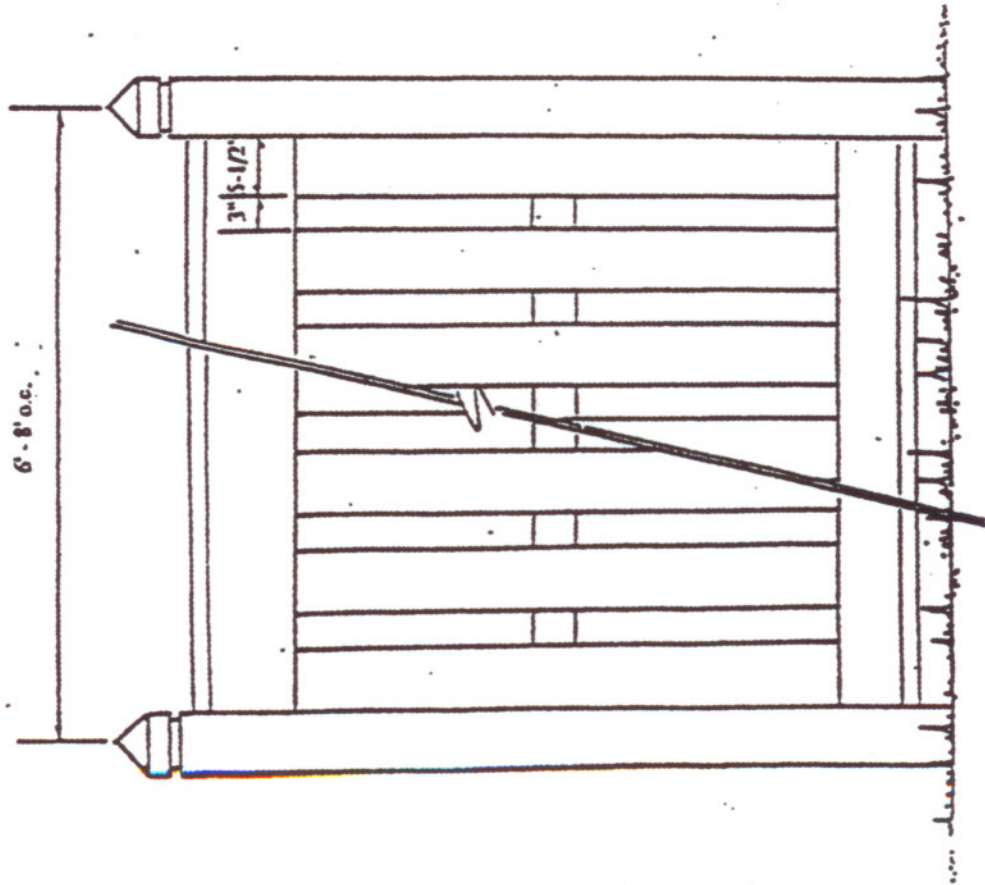

B. Wood Privacy Fence

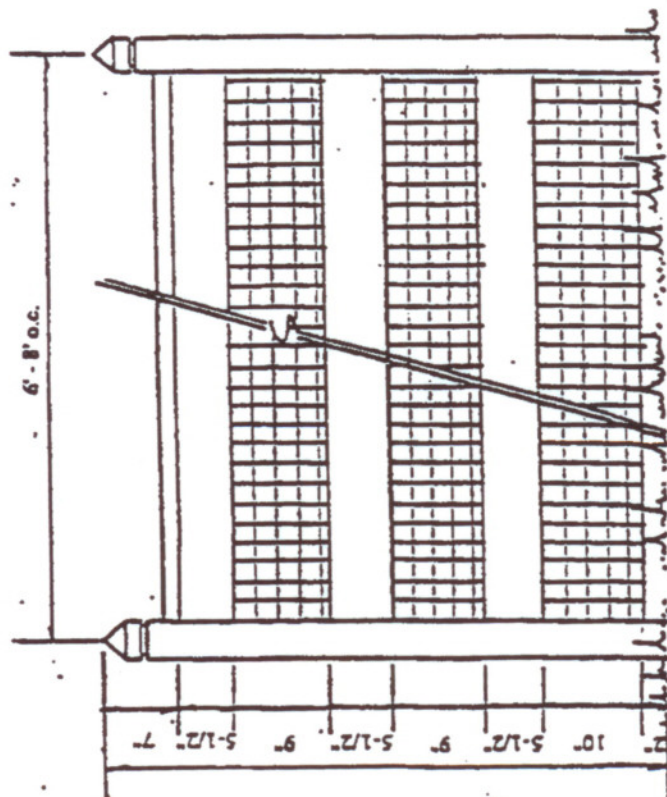
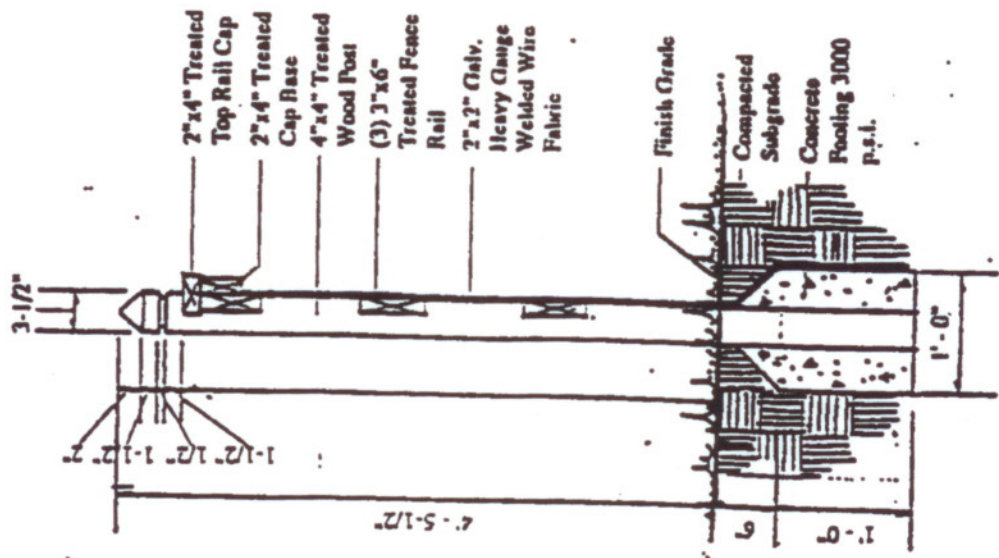

C. Wood Fence